

ENGINEERING DEPARTMENT
**SYSTEMS ENGINEERING
BRANCH**

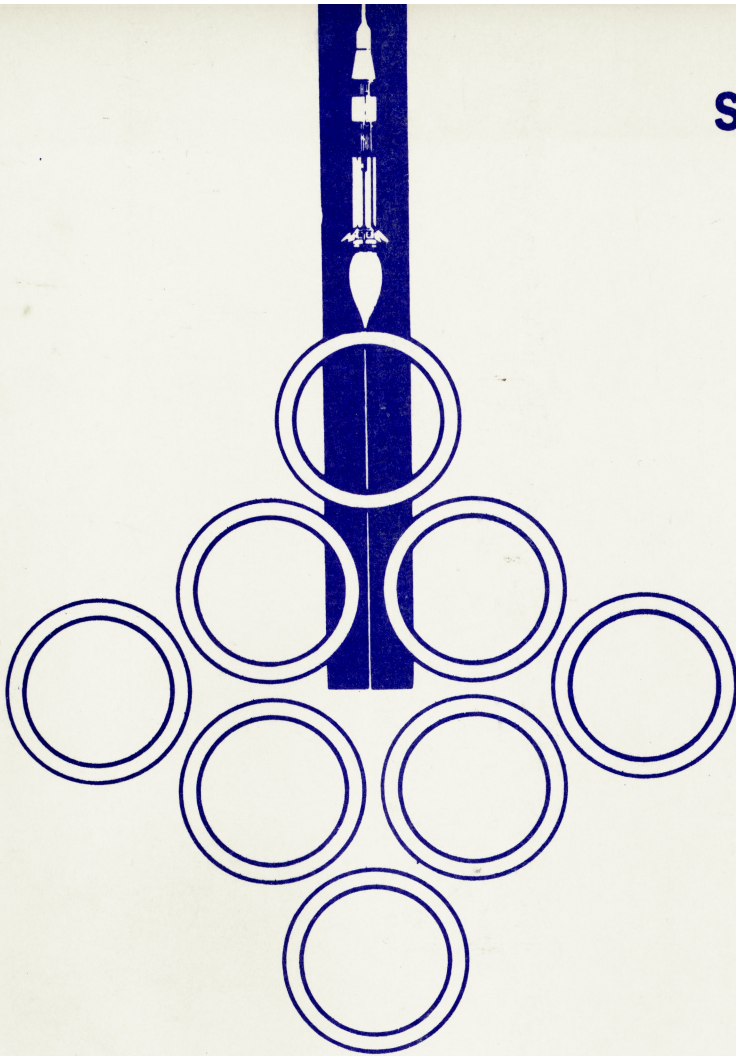

**APOLLO-SATURN AS-207
VEHICLE SYSTEMS INFORMATION DRAWINGS**

**PREPARED BY: SYSTEMS INTEGRATION ENGINEERING
[HTTP://HEROICRELICS.ORG](http://heroicrelics.org)**

SPACE DIVISION  **CHRYSLER
CORPORATION**

FOREWORD

The Vehicle Systems Information Drawings (VSID's) are produced for the Layout and Packaging Section, VSL, of the P&VE Laboratory, MSFC, by the Systems Engineering Branch, Chrysler Corporation Space Division under contract NAS 8-4016.

The purpose of the VSID's is to provide advanced reference information on the configuration and layout of each Saturn IB launch vehicle and payload. They are intended for use as an advanced vehicle configuration guideline throughout NASA and contractor organizations participating in the Saturn IB Program.

The drawings (1) assimilate new design information for future mission studies, analyses and evaluations, (2) provide a configuration baseline for the development of other special purpose vehicle drawings and operational data, and (3) can be used to assist in the coordination of design and manufacturing planning, transportation and handling planning, erection and test planning and facilities and services planning.

The drawings presented in this issue will be updated by drawing revision periodically as required to present current vehicle configuration. Drawing revisions will be issued to distribution for incorporation by the users.

TABLE OF CONTENTS

VEHICLE SYSTEMS INFORMATION DRAWINGS

DRAWING NUMBERS	TITLES
60C00721 Rev. A	Apollo-Saturn Vehicle Configuration
60C00722 Rev. A	Apollo-Saturn Vehicle Inboard Profile
60C00723 Rev. A	Apollo-Saturn Vehicle to GSE Information
60C00724 Rev. A	Apollo-Saturn Vehicle Access Provisions
60C00725 Rev. A	Apollo-Saturn Vehicle Antenna Arrangements
60C00726 Rev. A	Apollo-Saturn Vehicle Handling & Transportation
60C00727	S-IB Stage Assembly Layout, Apollo-Saturn
60C00728	S-IVB Stage Assembly Layout, Apollo-Saturn
60C00729	IU Assembly Layout, Apollo-Saturn
60C00730 Rev. A	Payload Assembly Layout, Apollo-Saturn
60C00731	S-IB Stage Hazardous Materials, Apollo-Saturn
60C00732	S-IVB Stage Hazardous Materials, Apollo-Saturn
60C00733 Rev. A	Payload Hazardous Materials, Apollo-Saturn

APPENDIX

DRAWING NUMBERS	TITLES
10M03604 Rev. F	Saturn IB Vehicles Nomenclature Chart
10M03681 Rev. H	Saturn IB Vehicles Information Drawing

DISTRIBUTION LIST

ORIGINAL ISSUE
16 NOV. 1966
EFFECTIVE AS-207

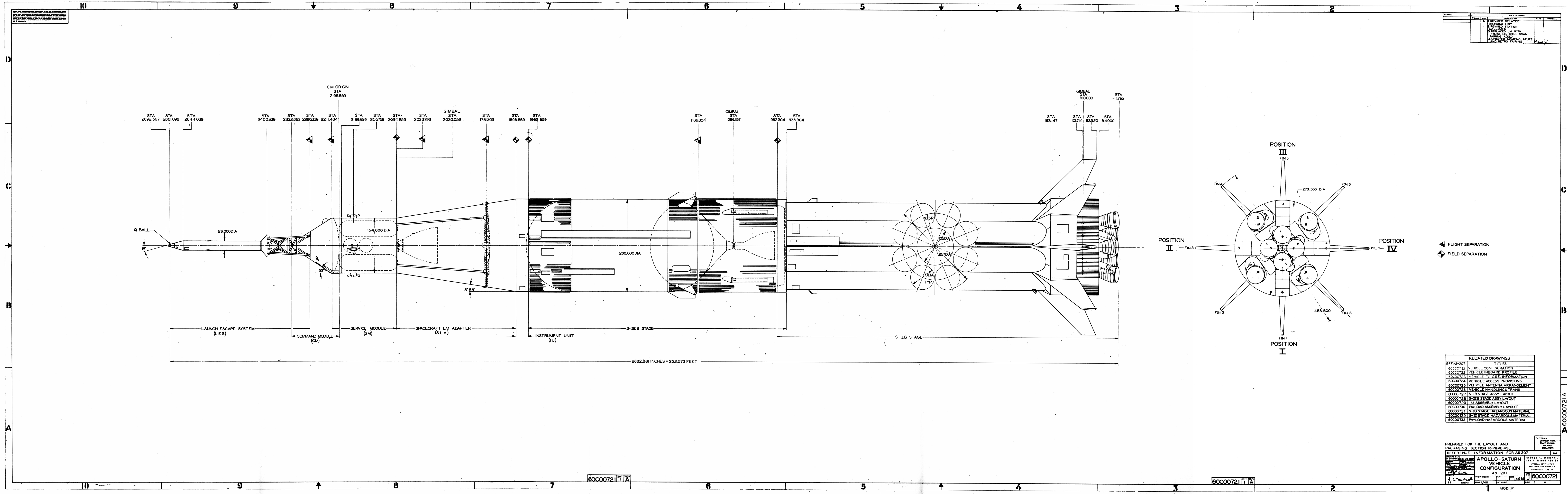

REV.	DATE	DESCRIPTION
1		REVISED RELATED DRAWING LIST
2		REPLACES LIST WITH FINISH LINE DOWN
3		REVISED NOMENCLATURE

NO.	TITLE
60000207	TITLES
60000201	VEHICLE CONFIGURATION
60000202	VEHICLE INBOARD PROFILE
60000203	VEHICLE TO GSE INFORMATION
60000204	VEHICLE ACCESS PROVISIONS
60000205	VEHICLE ANTENNA ARRANGEMENT
60000206	VEHICLE HANDLING & TRANS
60000207	S-IB STAGE ASSY LAYOUT
60000208	S-IB STAGE ASSY LAYOUT
60000209	IU ASSEMBLY LAYOUT
60000210	PAYLOAD ASSEMBLY LAYOUT
60000211	S-IB STAGE HAZARDOUS MATERIAL
60000212	S-IB STAGE HAZARDOUS MATERIAL
60000213	PAYLOAD HAZARDOUS MATERIAL

PREPARED FOR THE LAYOUT AND PACKAGING SECTION R-PAVE-VSL REFERENCE INFORMATION FOR AS 207 APOLLO-SATURN VEHICLE CONFIGURATION AS-207 14885 MOD 26	60000721 14885 MOD 26
--	-----------------------------

60000721 1A

60000721 1A

60000721 A

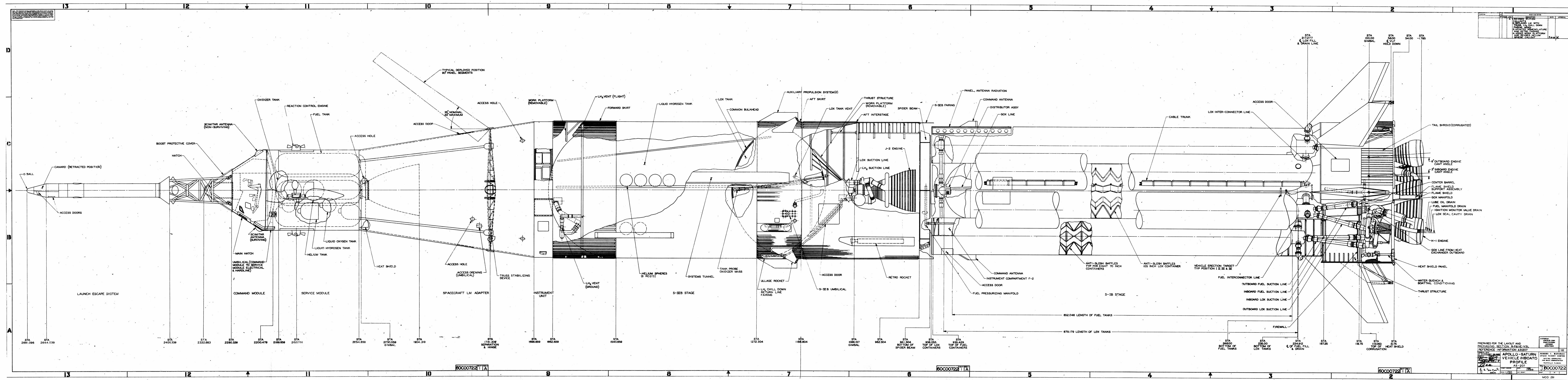

NO.	DESCRIPTION	DATE	BY	CHKD
1	ISSUED FOR LAYOUT AND PACKAGING SECTION R/P&VE-VSL			
2	REVISIONS			

PREPARED FOR THE LAYOUT AND PACKAGING SECTION R/P&VE-VSL
 REFERENCE INFORMATION AS-207
APOLLO-SATURN VEHICLE INBOARD PROFILE
 AS-207
 DATE 1/20/68
 MOD 28

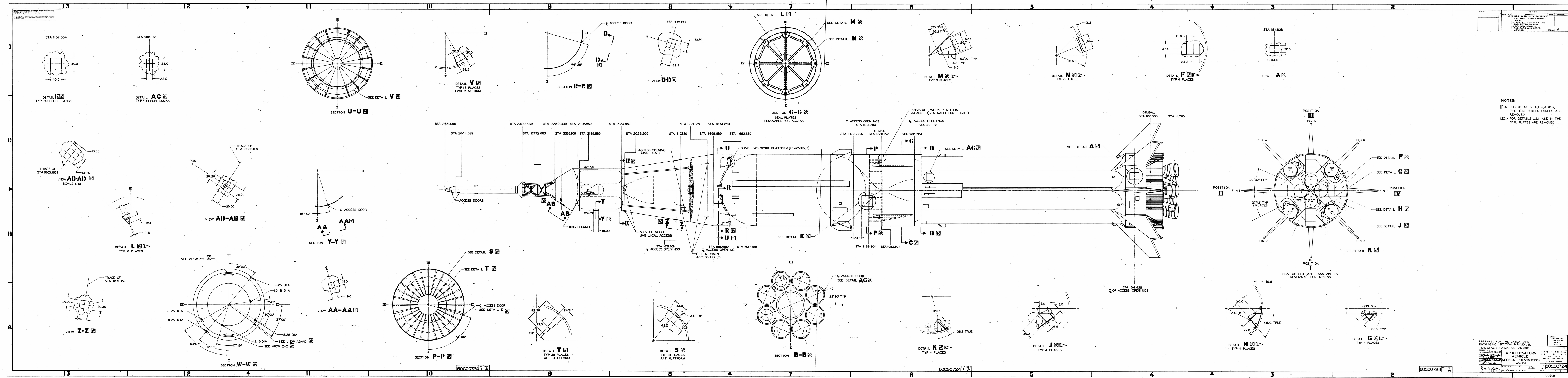

NO.	DESCRIPTION	DATE	BY	CHKD.
1	REPLACED BY 10/15/64			
2	REPLACED BY 10/15/64			
3	REPLACED BY 10/15/64			
4	REPLACED BY 10/15/64			
5	REPLACED BY 10/15/64			
6	REPLACED BY 10/15/64			
7	REPLACED BY 10/15/64			
8	REPLACED BY 10/15/64			
9	REPLACED BY 10/15/64			
10	REPLACED BY 10/15/64			
11	REPLACED BY 10/15/64			
12	REPLACED BY 10/15/64			
13	REPLACED BY 10/15/64			

NOTES:
 ▽ FOR DETAILS F, G, H, AND K, THE HEAT SHIELD PANELS ARE REMOVED.
 ▽ FOR DETAILS L, M, AND N, THE SEAL PLATES ARE REMOVED.

PREPARED FOR THE LAYOUT AND PACKAGING SECTION R-PAVE-VSL
 REFERENCE INFORMATION: A-5-207
 APOLLO-SATURN VEHICLE
 ACCESS PROVISIONS
 60C00724
 R. A. McGUIRE
 1/10/64

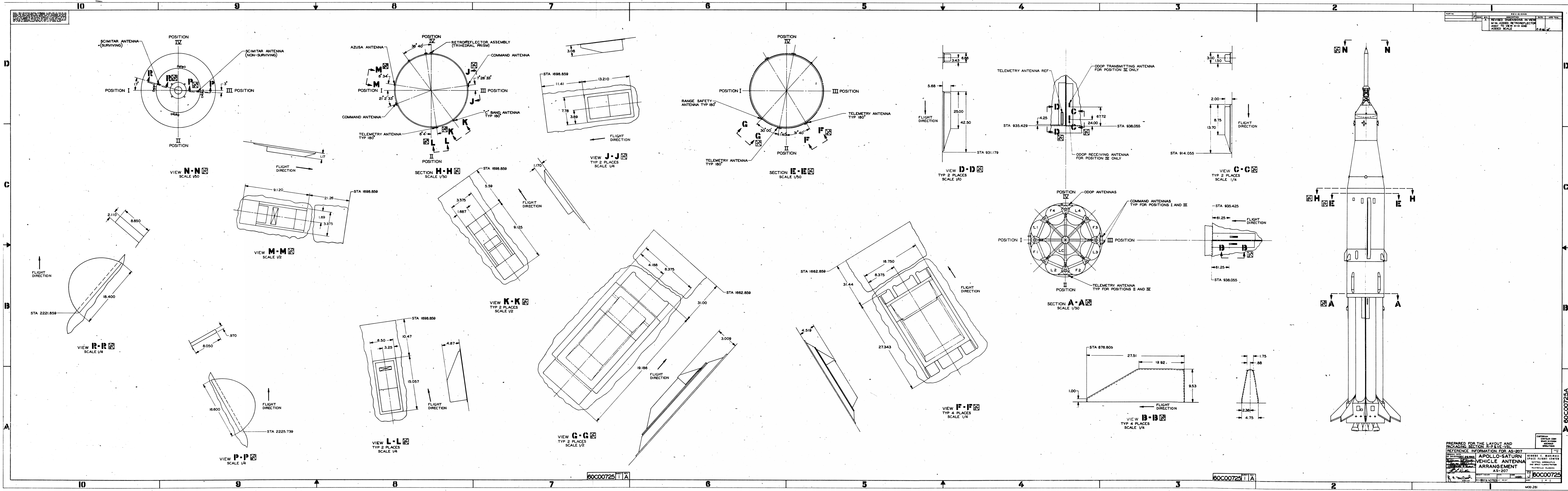

REVISED DIMENSIONS IN VIEW	DATE	BY
M-M, ADDED RETROREFLECTOR		
ADD TO VIEW WITH AND		
ADDED SCALE	1:2.41	

PREPARED FOR THE LAYOUT AND PACKAGING INFORMATION FOR AS-207	APOLLO-SATURN VEHICLE ANTENNA ARRANGEMENT	AS-207
APPROVED FOR THE LAYOUT AND PACKAGING INFORMATION FOR AS-207	APOLLO-SATURN VEHICLE ANTENNA ARRANGEMENT	AS-207
APPROVED FOR THE LAYOUT AND PACKAGING INFORMATION FOR AS-207	APOLLO-SATURN VEHICLE ANTENNA ARRANGEMENT	AS-207
APPROVED FOR THE LAYOUT AND PACKAGING INFORMATION FOR AS-207	APOLLO-SATURN VEHICLE ANTENNA ARRANGEMENT	AS-207

60C00725A
 MOD 28

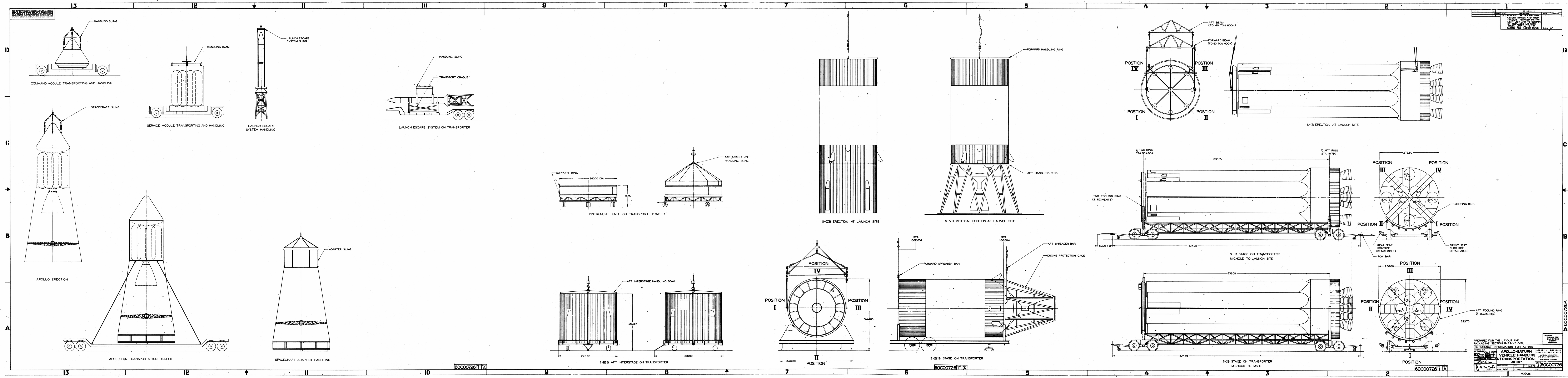

PREPARED FOR THE LAYOUT AND PACKAGING SECTION BY P & E - VSL
 REFERENCE INFORMATION FOR AS-207
 APOLLO-SATURN VEHICLE HANDLING & TRANSPORTATION AS-207
 14388
 80C00726
 MOD 281

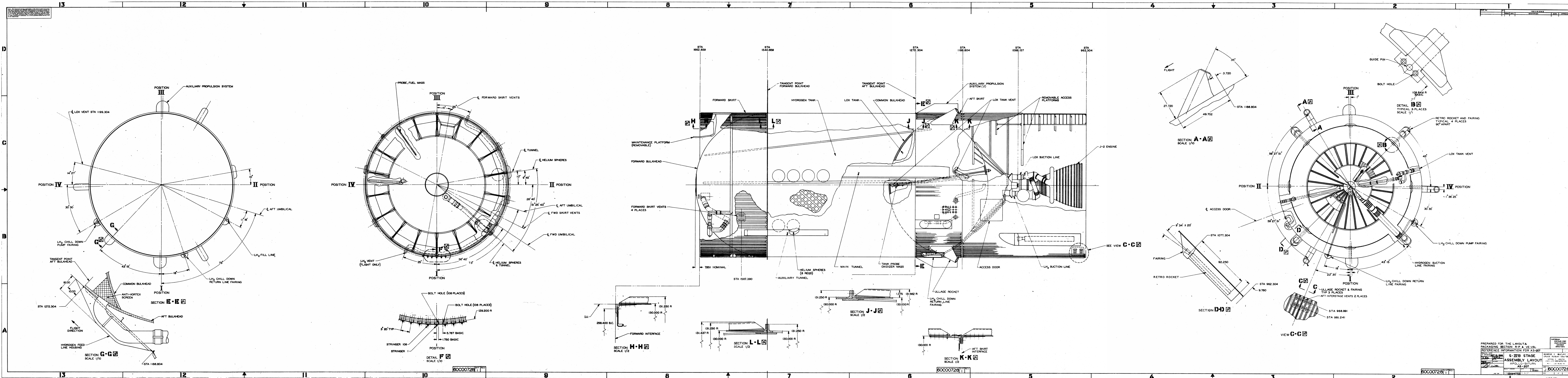

PREPARED FOR THE LAYOUT & PACKAGING SECTION R-P & VE-VSL
 REFERENCE INFORMATION FOR AS-207
 S-IVB STAGE
 ASSEMBLY LAYOUT
 AS-207
 60000728
 MOD 28

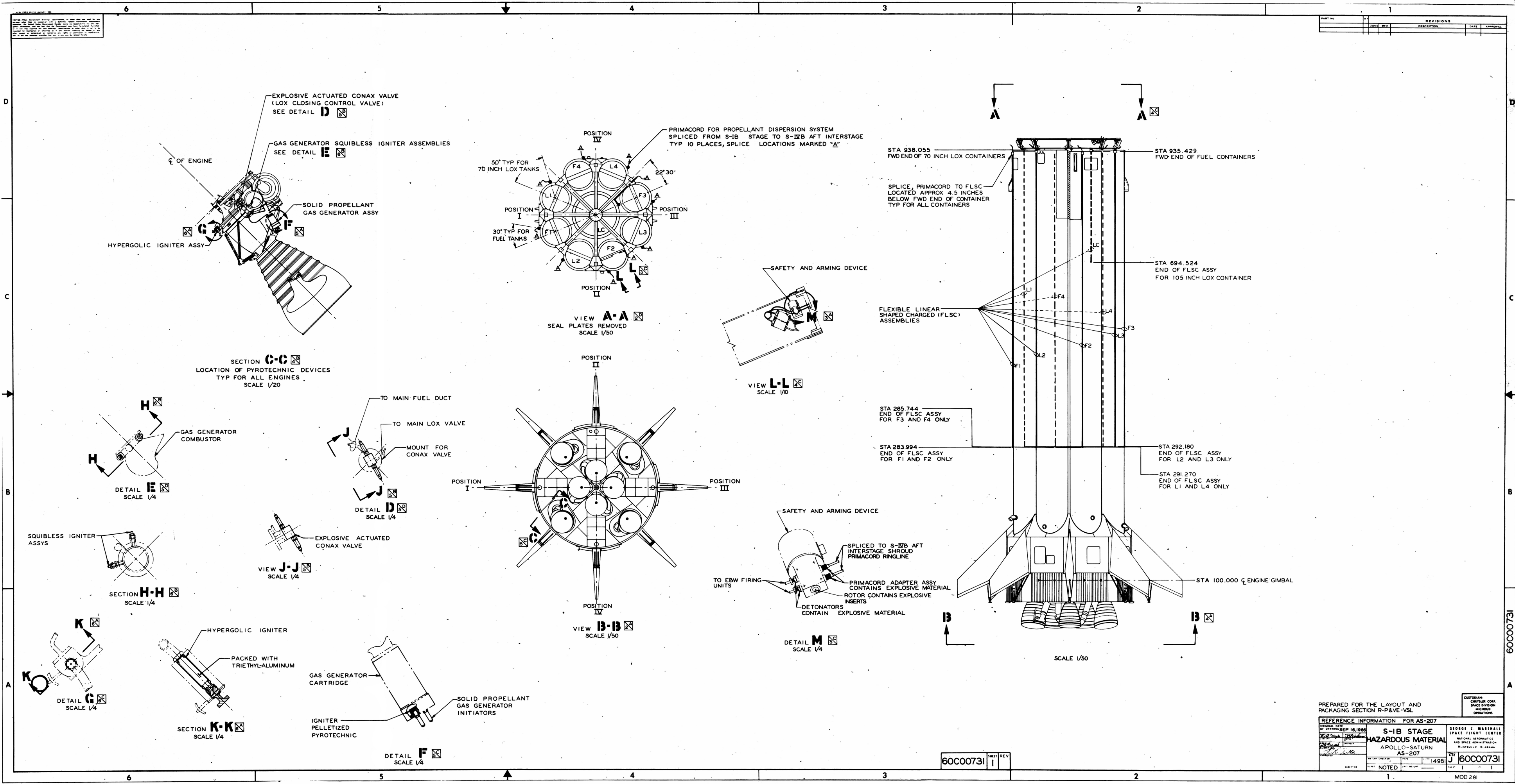

PART NO.		REV		REVISIONS		DATE		APPROVAL	

PREPARED FOR THE LAYOUT AND PACKAGING SECTION R-P&VE-VSL

CUSTOMER: CHRYSLER CORP SPACE DIVISION MISSOURI OXFORD TOWNSHIP

REFERENCE INFORMATION FOR AS-207

DATE: SEP 16 1966

HAZARDOUS MATERIAL

APOLLO-SATURN

AS-207

REV J 1498

60C00731

NOTED

MOD 281

60C00731 SHEET 1 REV 1

60C00731

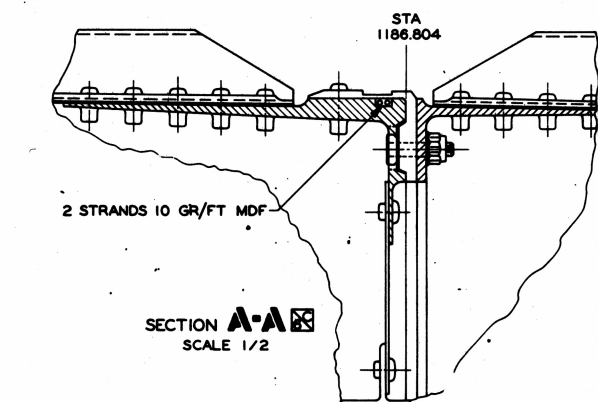
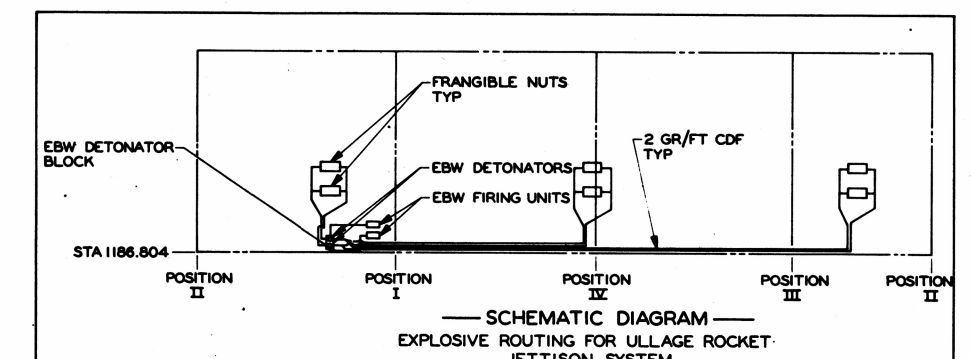
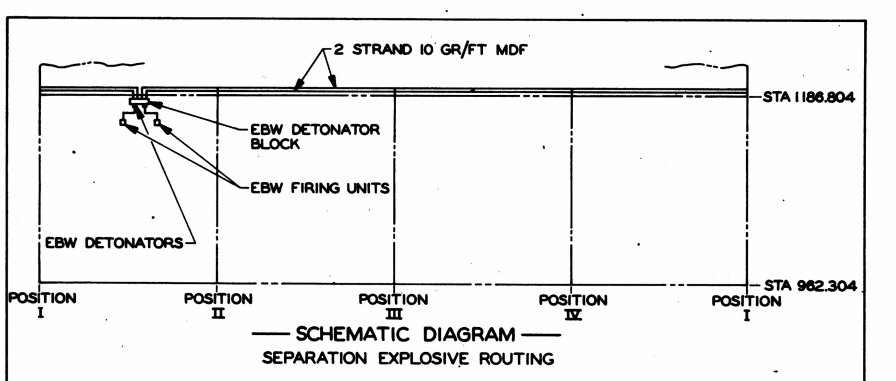
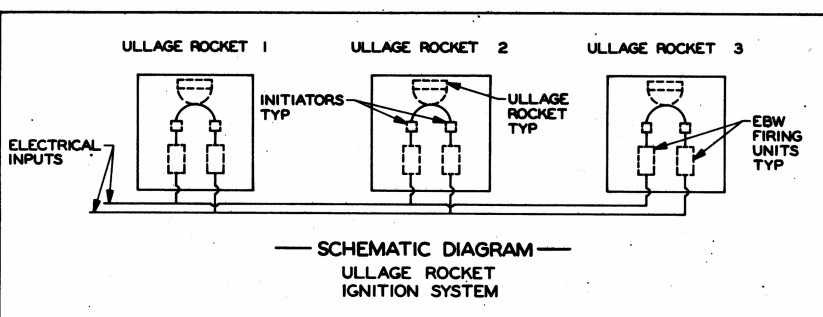
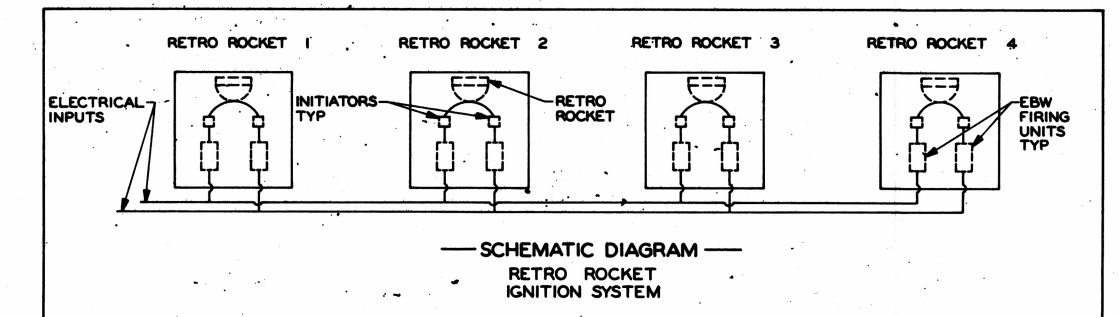
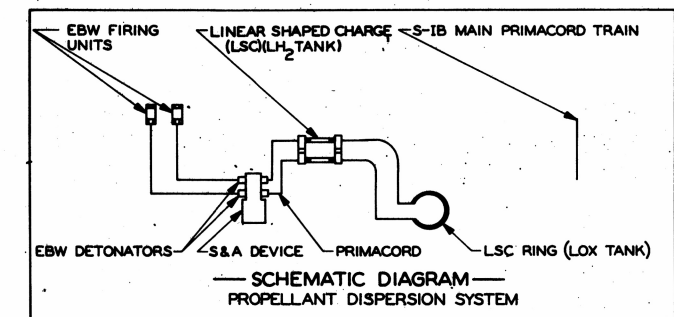
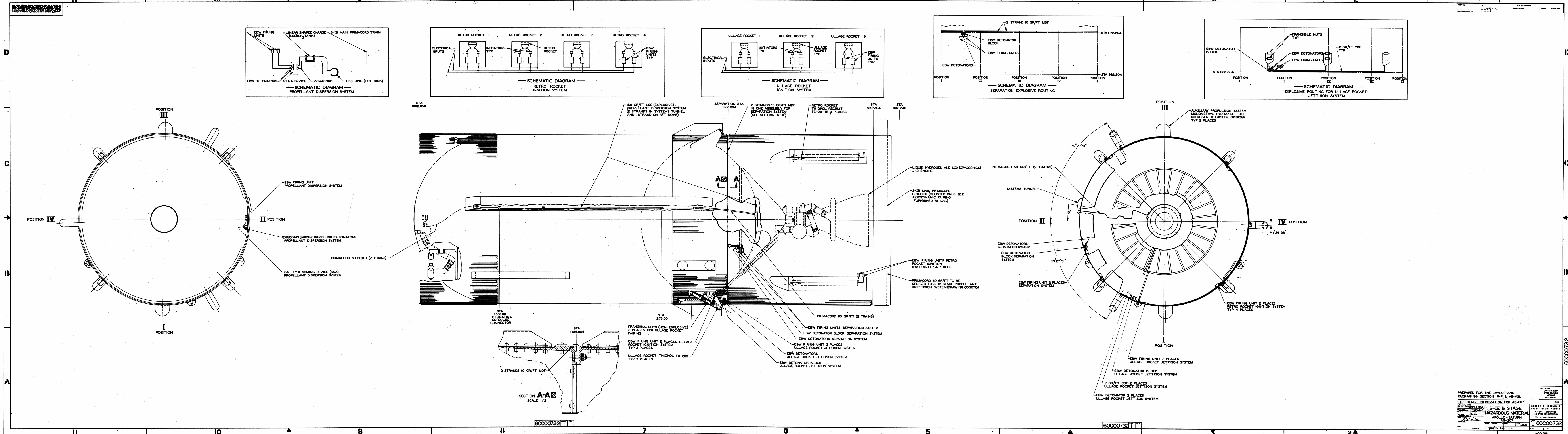

PREPARED FOR THE LAYOUT AND PACKAGING SECTION R-P & VE-VSL
 REFERENCE INFORMATION FOR AS-207
S-IV B STAGE
HAZARDOUS MATERIAL
 APOLLO-SATURN
 AS-207
 60C00732
 MOD 28

REV.	DESCRIPTION	DATE	INITIALS
A	REMOVED LM AND ASSOCIATED DETAILS AND ADDED CORRECTED FORWARD END VIEW AND RELATED PROJECTIONS ADDED SECTION F-F UPDATED CALLOUTS AND ADDED SCALE	1-14-68	R. J. ...

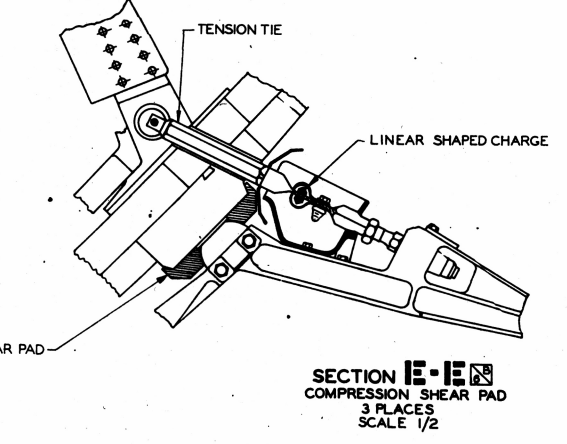
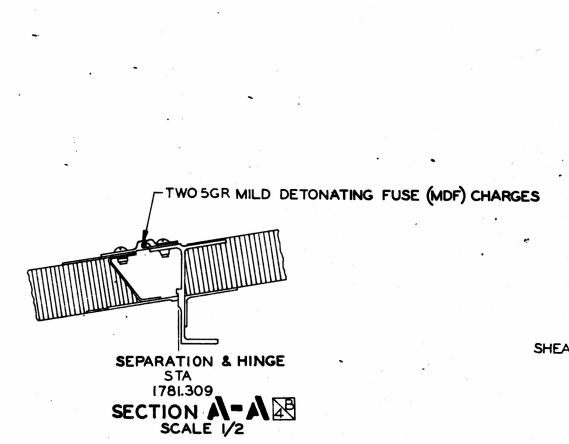
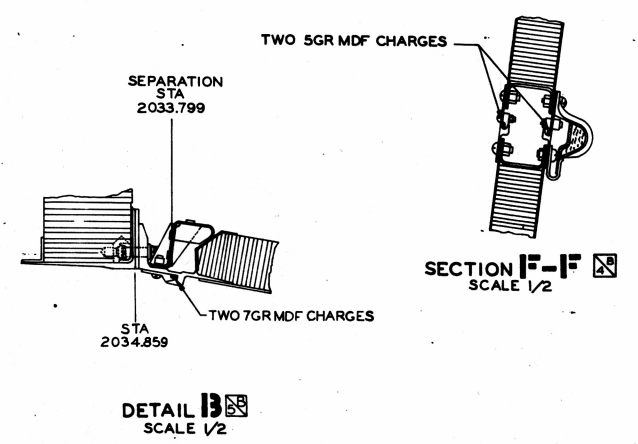
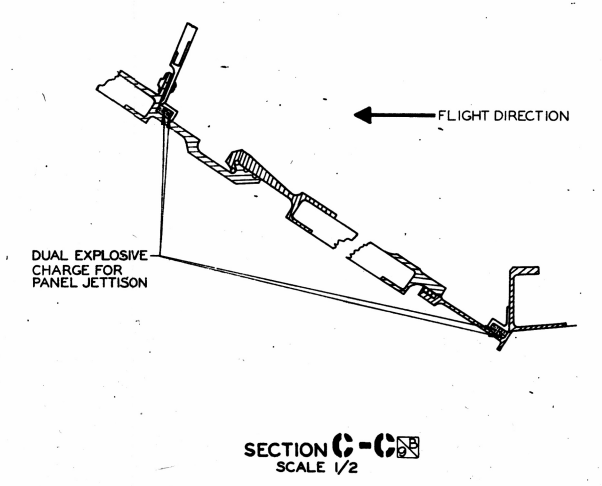
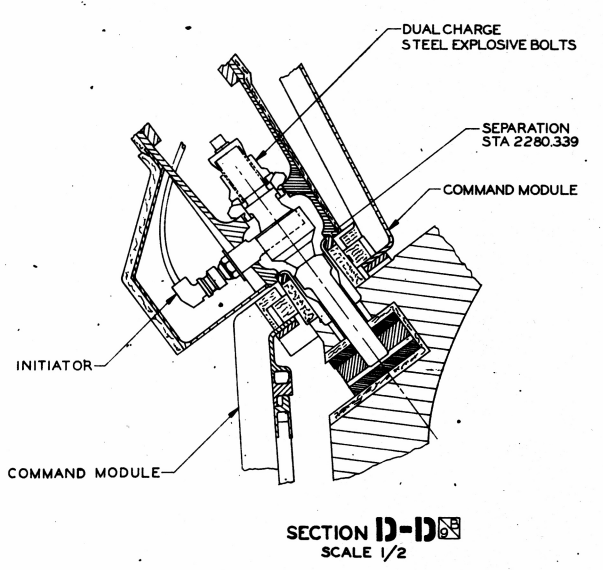
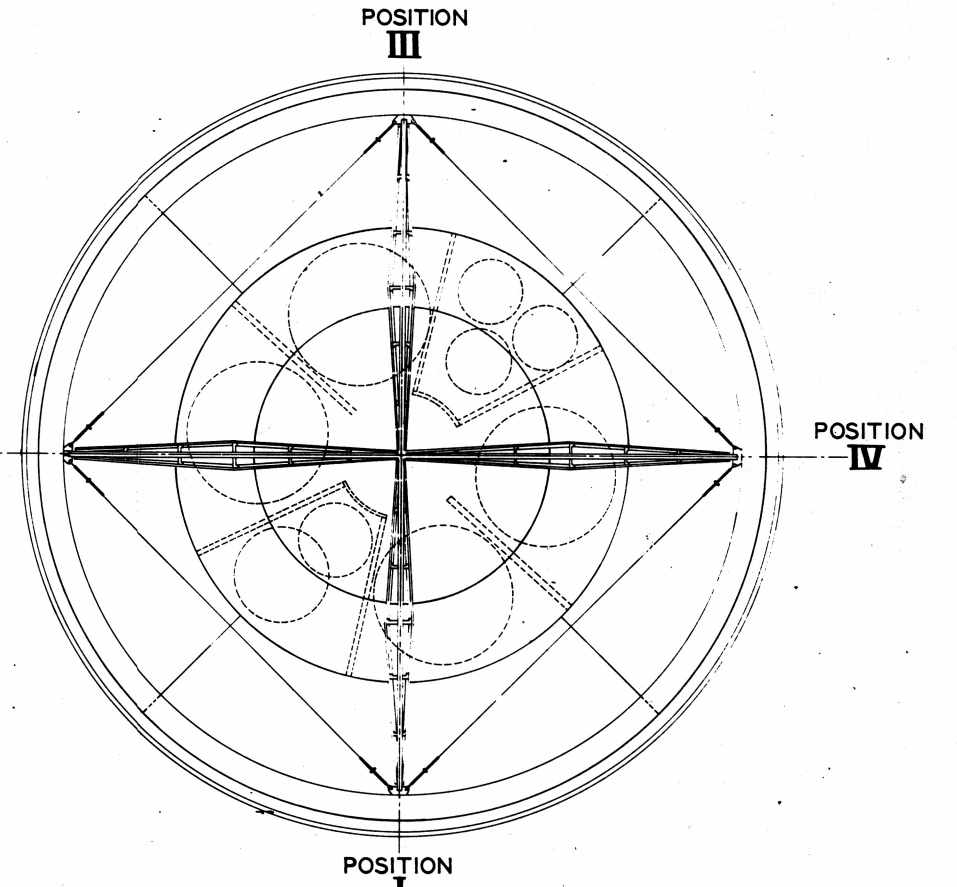
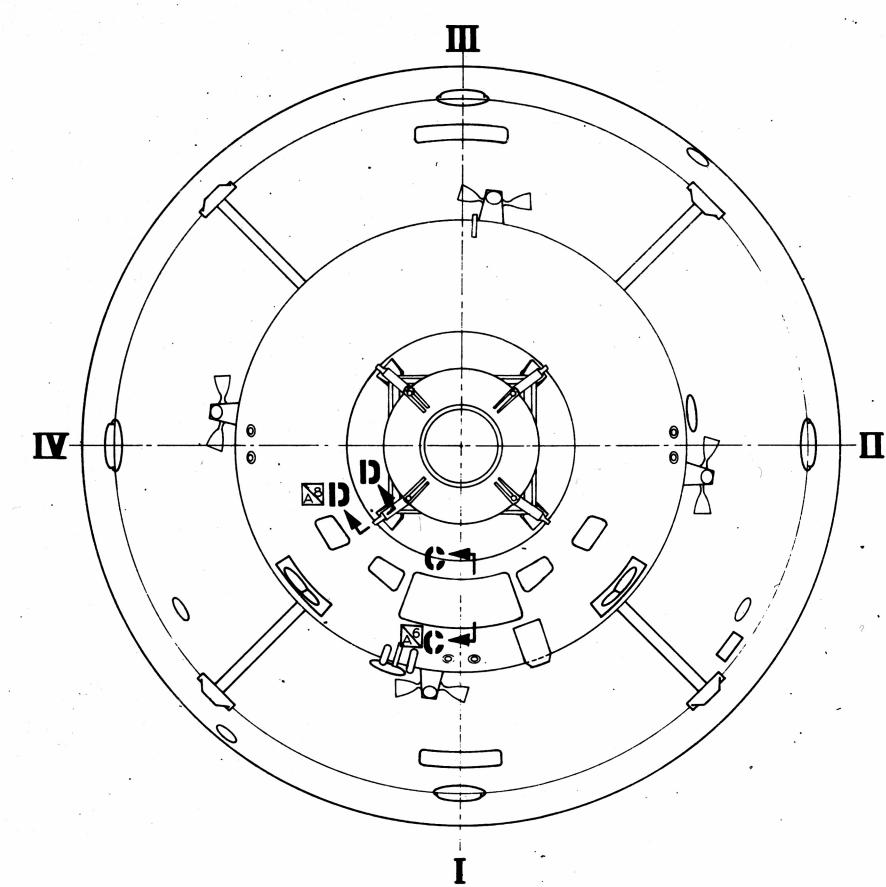
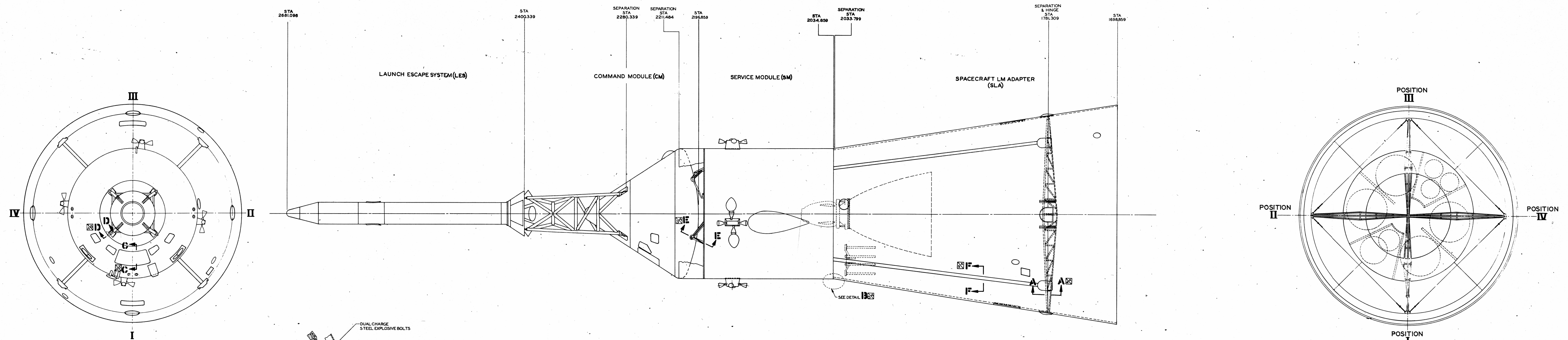

60C00733 1 A

60C00733 1 A

PREPARED FOR THE LAYOUT AND PACKAGING SECTION R-PAVE-VSL REFERENCE INFORMATION FOR AS-207 DATE: DEC 1968 DRAWING NO: 60C00733 SCALE: 1/2 SHEET: 14 OF 14	PAYLOAD APOLLO-SATURN AS-207 HAZARDOUS MATERIAL 14981	ROBERT L. BARRELL STEEL FILLET CENTER AIR FORCE OPERATIONS 400 WACE DRIVE HUNTSVILLE, ALABAMA 35894 60C00733 MOD 281
---	---	---

60C00733A

SATURN IB VEHICLES

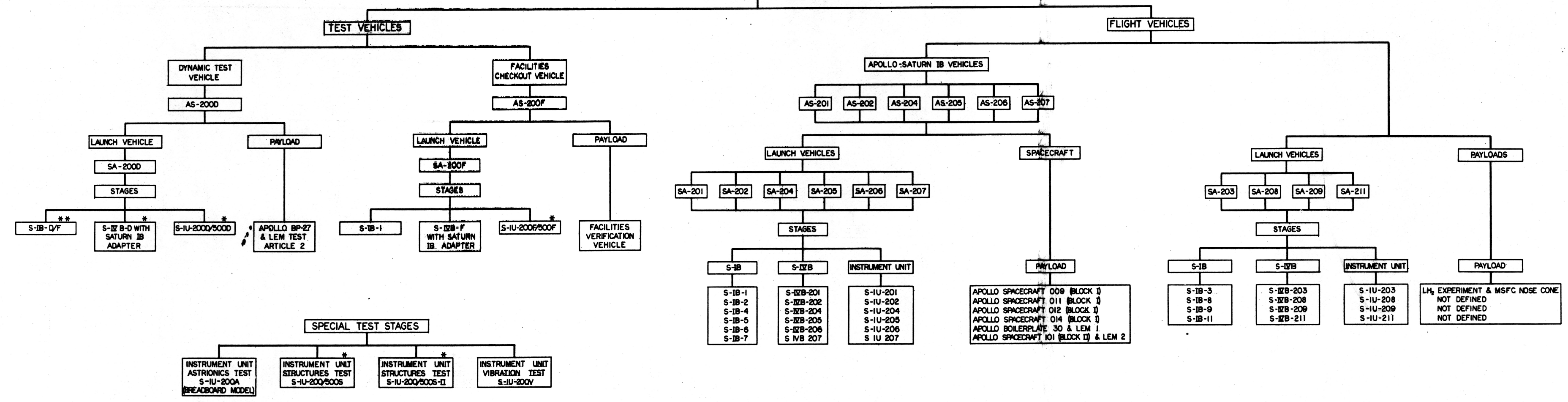

NOTE:
 VEHICLES SA-210 & SA-212 ARE SCHEDULED FOR THE SATURN IB/CENTAUR PROGRAM
 *STAGE USED FOR BOTH SATURN IB & SATURN V TESTING
 ** CONVERTED SA-D5 STAGE

Layout and Human Engineering Section
 R-P&VE-VSL

REV	DESCRIPTION	DATE	BY	CHKD
A	REVISED STATIONS ON SA-200 PAYLOAD ADDED PAYLOAD TO AS-205	10/24/66	WMM	SLT/MSK
B	REVISED STATIONS ON AS-201 AS-202	10/24/66	WMM	SLT/MSK
C	REVISED STATIONS ON AS-201 AS-202	10/24/66	WMM	SLT/MSK
D	REVISED STATIONS ON AS-201 AS-202	10/24/66	WMM	SLT/MSK
E	REVISED STATIONS ON AS-201 AS-202	10/24/66	WMM	SLT/MSK
F	REVISED STATIONS ON AS-201 AS-202	10/24/66	WMM	SLT/MSK
G	REVISED STATIONS ON AS-201 AS-202	10/24/66	WMM	SLT/MSK
H	REVISED STATIONS ON AS-201 AS-202	10/24/66	WMM	SLT/MSK

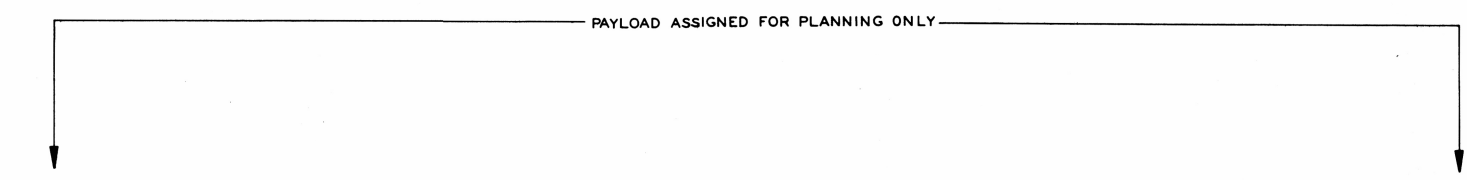
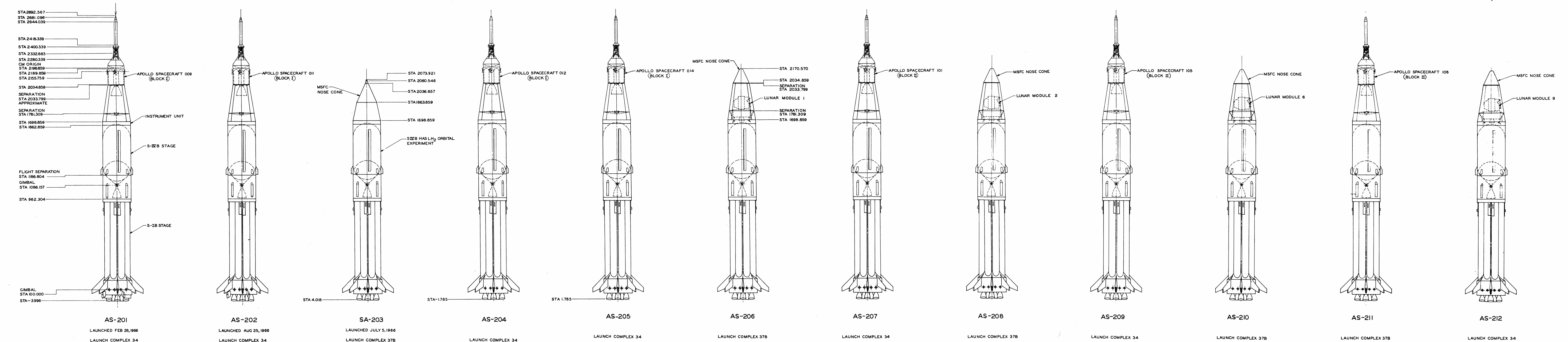

LAYOUT & PACKAGING SECTION R-P & VE-VSL	
DATE: 10/24/66	SCALE: AS SHOWN
DESIGNED BY: [Signature]	CHECKED BY: [Signature]
DRAWN BY: [Signature]	APPROVED BY: [Signature]
INFORMATION DRAWING	
SATURN IB	
VEHICLES	
NO. 1003681	REV. 1

10M03681

10M03681

DISTRIBUTION LIST

NASA - MSFC

E-P, Mr. Abbott	R-QUAL-P, Mr. Hall
MS-G, Mr. Chandler	R-TEST-C, Mr. Grafton
MS-GM, Mr. Rives	R-TEST-BD, Mr. Chumley
I-I/IB-MGR, Mr. Chevaillier	R-TEST-S, Mr. Driscoll
I-I/IB-E, Mr. Germany	R-P&VE-X/KSC, Mr. Phillips
I-I/IB-E, Mr. Cantrell	R-P&VE-XJ/SACTO, Mr. Sheridan
I-I/IB-E, Mr. Dohm	R-P&VE-XB, Mr. Rothe
I-I/IB-E, Mr. Galloway	R-P&VE-XC, Mr. Lawson
I-I/IB-G, Mr. Dunlap	R-P&VE-XJ, Mr. Griner
I-I/IB-U, Mr. Simmons	R-P&VE-XK, Mr. Boone
I-MO-MGR, Dr. Speer	R-P&VE-AB, Mr. Kromis
I-RM, Mr. Bullington	R-P&VE-AB, Mr. Laue
R-AS-VO, Mr. D. Cramblet	R-P&VE-PA, Mr. Thompson
R-OM-V, Mr. McCrary	R-P&VE-PE, Mr. Holmes
R-AERO-A, Mr. Dahm	R-P&VE-PAS, Mr. Long
R-AERO-ADE, Mr. Andrews	R-P&VE-FM, Mr. Fuhrmann
R-AERO-ADV, Mr. Dunn	R-P&VE-FMP, Mr. Barnes
R-AERO-AEM, Mr. Love	R-P&VE-PPF, Mr. Askew
R-AERO-D, Mr. Verderaime	R-P&VE-PTF, Mr. Platt
R-AERO-F, Mr. Lindberg	R-P&VE-PPS, Mr. Eilermann
R-AERO-P, Mr. Teague	R-P&VE-S, Mr. Verble
R-AERO-P, Mr. McNair	R-P&VE-SAE, Mr. Walters
R-ASTR-A, Mr. Digesu	R-P&VE-SL, Mr. Showers
R-ASTR-EA, Mr. Smith	R-P&VE-SS, Mr. Frederick
R-ASTR-F, Mr. Hosenthien	R-P&VE-SVR, Mrs. Mowell
R-ASTR-IE, Mr. Cox/Banks	R-P&VE-VAW, Mr. Scott
R-ASTR-IM, Mr. Paludan	R-P&VE-VN, Mr. Beck
R-ASTR-IR, Mr. Barr	R-P&VE-VN, Mr. Owens
R-ASTR-NDF, Mr. Garrett	R-P&VE-VOU, Mr. Jankowski
R-ASTR-NG, Mr. Seltzer	R-P&VE-VOO, Mr. Balch
R-QUAL-A, Mr. Henritze	R-P&VE-VOI, Mr. Sells
R-QUAL-OE, Mrs. Richardson	R-P&VE-X/CCSD, Mr. Misner (2)
R-P&VE-VSL, Mr. Strider (12)	

NASA - MSC

R-1/MSC (Houston), Mr. Davidson

NASA - KSC

EDV-15, Mr. Moore
EDV-15, Mr. Herold
EDV-17, Mr. Batson
EDV-18, Mr. B. Nelson
EDV-22, Mr. A. Carraway
EDV-29, Mr. J. Feusner
EDV-295, Mr. C. Stewart
INS-4, Mr. Collins
INS-4, Mr. Payne
JA-10, Mr. J. Devault
JB-10, Mr. M. Chambers
JB-20, Mr. W. O. Chandler
JB-20, Mr. F. Bryan
JB-30, Mr. C. A. Whiteside

JC-00, Mr. M. D. Edwards
JC-00, Mr. W. R. Dietz
JC-00, Mr. S. S. Tucker
JC-11, Mr. J. S. Bizzell
JC-12, Mr. L. S. Blanchard
JC-20, Mr. J. J. Fitzgerald
JC-10, Mr. D. C. McMath
JD-00, Mr. L. Fannin
MC, Mr. J. Claybourne
MD, Mr. Poppel
ME, Mr. J. White
MH, Mr. C. Wasileski
MJ, Mr. G. Williams
SOP-1, Mr. Gorman

Mr. Jerry Reich Dept. 5450
Lockheed Missiles and Space
4800 Bradford Drive
Huntsville, Alabama

CCSD - MICHOU

M. T. Kirkenmeier	Vehicle Systems Integration
R. L. Wiltse	Systems Engineering Branch
E. J. Dofter	Reliability Engineering Branch
C. C. Gage	Prop. & Veh. Engineering Branch
D. E. Gero	Electrical Engineering Branch
D. N. Buell	Advanced Engineering Branch
C. E. Tharratt	Advanced Engineering Branch
W. R. Baldwin	Advanced Engineering Branch
R. Ross	Aero-Space Physics Branch
R. A. Walters	Systems Stage Section
H. B. Christiansen	Systems Stage Section
T. R. Cotter	Vehicle Engineering Section
G. Timm	Documentation & Drafting Section
E. M. Wilson	Inspection Services Section
B. B. Bender	Manufacturing Engineering Branch
T. H. Sandercock	Production Engineering Manufacturing
B. A. Tansil	Operation Plan. & Std's. Engineering
W. G. Juntunen	Operation Plan. & Std's. Engineering
C. E. Thomas	Electrical Systems Section
B. F. Elam	Aeroballistics Engineering Section
L. F. Smith	Systems Integration Section
M. J. Seals	Systems Integration Section
R. W. Fullerton	Systems Integration Section
W. W. Newgeon	Systems Test Operation
C. Gordon	Systems Test Operation
D. J. Sharp	Vehicle Engineering Section

CCSD-FLORIDA OPERATIONS

W. M. McCaughlin	Launch Equipment Group
P. M. Daniel	Launch Equipment Group
B. R. Bigham	Launch Equipment Group
M. T. Fleming	Launch System Engineering Group
L. H. Yount	Systems Launch Branch
P. F. Fahey	Launch Engineering Branch
J. E. Call	Test Operations
G. D. Baker	Launch Equipment Engineering Section
G. A. Greathouse (5)	Quality Assurance
J. Fields	Mechanical Propulsion Section
W. I. Jeffords	Configuration Control Unit
J. W. Broadbent	Instrumentation & RF Section
W. O. Brown	Electrical & Flight Controls Section
W. F. Koch	Program Office
F. A. Donovan	Design & Drafting Group
M. J. Peacock	Test Operations
J. H. Starkey	Test Operations
W. E. Dempster	Launch Systems Engineering Group
E. E. Chapple	Propellants Systems Group
G. L. Christen	Technical Staff
G. Salvador (3)	Prop. & Vehicle Mechanical Group

CCSD - FLORIDA OPERATIONS (Con't.)

D. W. Kelley	Airborne Networks Group
G. F. Anderson	Systems Studies Unit
J. F. Collins	Mechanical & Swing Arms Unit
D. T. Norton	Pneumatics Unit
J. L. Hoffman	Pneumatics Unit
A. M. Richard	Configuration Control Office
E. R. Dziadon	Launch Equipment Group
N. J. Goodsell	Launch Equipment Group
A. W. Schevling	Launcher/Structural Unit
J. O. Weldon	Systems Analysis Unit

CCSD-HUNTSVILLE OPERATIONS

J. D. Clifford	Engineering
H. Bader	Structures & Mechanics Engineering
W. C. Ragsdale	Engineering Communications Dept.
W. M. Cannizzo	Prop. & Mech. Branch
G. Martin	Structures Branch
W. J. Lambert	Ground Support Equipment Group
W. S. Ray	Engineering Communications Branch
J. A. Drummond	Structures & Mechanics Engineering
P. E. Beck	Mechanical Support Equipment Branch

SATURN IB VEHICLE SYSTEMS INFORMATION DRAWINGS

DRAWING INDEX

DRAWING TITLES	201	202	203	204	205	206	207	208	209	210	211	212
APOLLO-SATURN VEHICLE CONFIGURATION	60C00601	60C00621	60C00641	60C00661	60C00701	60C00721	60C00741	60C00761	60C00781	60C00801	60C00821	
APOLLO-SATURN VEHICLE INBOARD PROFILE	60C00602	60C00622	60C00642	60C00662	60C00702	60C00722	60C00742	60C00762	60C00782	60C00802	60C00822	
APOLLO-SATURN VEHICLE TO G.S.E. INFORMATION	60C00603	60C00623	60C00643	60C00663	60C00703	60C00723	60C00743	60C00763	60C00783	60C00803	60C00823	
APOLLO-SATURN VEHICLE ACCESS PROVISIONS	60C00604	60C00624	60C00644	60C00664	60C00704	60C00724	60C00744	60C00764	60C00784	60C00804	60C00824	
APOLLO-SATURN VEHICLE ANTENNA ARRANGEMENTS	60C00605	60C00625	60C00645	60C00665	60C00705	60C00725	60C00745	60C00765	60C00785	60C00805	60C00825	
APOLLO-SATURN VEHICLE HANDLING & TRANS	60C00606	60C00626	60C00646	60C00666	60C00706	60C00726	60C00746	60C00766	60C00786	60C00806	60C00826	
S-IB STAGE ASSEMBLY LAYOUT APOLLO-SATURN	60C00607	60C00627	60C00647	60C00667	60C00707	60C00727	60C00747	60C00767	60C00787	60C00807	60C00827	
S-IV B STAGE ASSEMBLY LAYOUT APOLLO-SATURN	60C00608	60C00628	60C00648	60C00668	60C00708	60C00728	60C00748	60C00768	60C00788	60C00808	60C00828	
TU ASSEMBLY-LAYOUT APOLLO-SATURN	60C00609	60C00629	60C00649	60C00669	60C00709	60C00729	60C00749	60C00769	60C00789	60C00809	60C00829	
PAYLOAD ASSEMBLY LAYOUT APOLLO-SATURN	60C00610	60C00630	60C00650	60C00670	60C00710	60C00730	60C00750	60C00770	60C00790	60C00810	60C00830	
S-IB STAGE HAZARDOUS MATERIAL APOLLO-SATURN	60C00611	60C00631	60C00651	60C00671	60C00711	60C00731	60C00751	60C00771	60C00791	60C00811	60C00831	
S-IV B STAGE HAZARDOUS MATERIAL APOLLO-SATURN	60C00612	60C00632	60C00652	60C00672	60C00712	60C00732	60C00752	60C00772	60C00792	60C00812	60C00832	
PAYLOAD HAZARDOUS MATERIAL APOLLO-SATURN	60C00613	60C00633	N/A (60C00653)	60C00673 (60C00673)	60C00713 (60C00683)	60C00733	60C00753	60C00773	60C00793	60C00813	60C00833	

NOTES:

I DRAWING NUMBERS SHOWN IN PARENTHESIS ARE RESERVED FOR USE AS REQUIRED

FEB 14, 1966
APR 15, 1966
MAY 23, 1966
JULY 25, 1966